

Guidance for Construction on Gas Contaminated Land and Installation Guidelines for Gas Barrier Systems



Guidance for construction of new dwellings on gas contaminated land.

Assessing the risk:

It is a requirement of National Planning Policy Framework and Building Regulations Approved Document C, that where the proposed structure is at risk from gas contaminated land the developer must carry out a risk assessment for submission to the local planning authority. The types of ground gasses commonly encountered are:

Radon Gas – A colourless, odourless naturally occurring radioactive gas.

This gas is prevalent in granite areas but can occur almost anywhere. Granite is naturally rich in uranium. It is widely held that exposure to Radon Gas is a major cause of lung cancer.

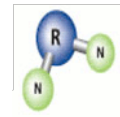

Methane Gas – A colourless gas formed by the decomposition of organic material.

The gas is flammable and potentially explosive even in relatively low concentrations.

This gas is common on or near landfill sites, mining areas etc. This gas becomes explosive at concentrations of 5% subject to an ignition source.

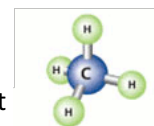

Carbon Dioxide – A colourless gas which in sufficient concentrations can cause asphyxiation.

Often associated with landfill areas it is formed by the oxidation of carbon.

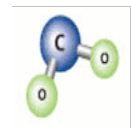

Hydrocarbons – A range of hazardous substances often associated with the

petrochemical industry. Typically found in disused petrol stations and industrial sites.

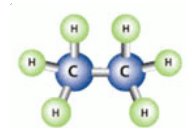

System solutions:

The Rhinoplast range of Gas Barrier Systems has been designed to provide a complete solution to the problems associated with construction on land associated with a range of hazardous gasses, when installed in accordance with the relevant codes of practise. The primary method of protection to the structure is by way of a complete “ footprint “ membrane system combined with underfloor passive venting. The key to a successful outcome is installation. The best membranes poorly installed are likely to fail. The Rhinoplast range includes pre-formed details and tapes to facilitate this. Where necessary we will provide on-site advice and training to ensure a successful outcome.

We even offer a “ pre pour “ inspection service to ensure correct installations and detailing.

These barriers are designed to protect structures and inhabitants from the effects of these gasses. They will also act as damp-proof membranes where applicable and are intended to last the life time of the building. All of our membranes can be welded.

With the increase in awareness of such gasses, along with more and more stringent requirements, it is becoming more and more important for contractors to use “ fit for purpose materials “ in the secure knowledge that they will perform satisfactorily.

As pressure mounts on the construction industry to build on “ Brown Field Sites “ the demand for these products is increasing daily.

Gas Barrier Installation Method:

General:

The Rhinoplast range of gas barrier systems has been carefully designed to provide everything required to complete a safe and successful installation. Our membranes are technically advanced and the components rigorously tested to ensure the system will perform correctly and keep the structure safe from harmful ground gasses, however poor installation can and will compromise the outcome. Good workmanship and attention to detail are therefore of paramount importance.

Our system components are matched to the barriers and should not be substituted as doing so could compromise the installation.

It is vital for the system to work correctly, that a gas tight footprint is created for the structure, and detailed through the walls to the outside. Particular care should be taken when jointing and detailing. Ensure the area which the membrane is going to cover is swept free of all debris likely to cause puncture such as brick or block fragments or dried mortar. Where this is not possible the area under the membrane should be protected by sand blinding to a depth of 50mm. The area should be dry and the temperature 5°C or above. Between 5°C and 10°C it may be necessary to apply heat to the tape for good adhesion. Take care not to expose the area to excessive foot traffic and avoid accidental damage during installation and before the concrete is poured. Where this is impractical protection boards should be used. Lay the membrane over the footprint of the building, taking care to allow for a minimum of 150mm overlaps. Ensure the membrane is as flat as possible to the ground, and tucked neatly into the floor to wall angle to avoid excess voiding.

Where the Rhinoplast LT Jointstrip joins at 90 degrees, it is vital that a neat “butt” joint is achieved. All joints should be over-taped to protect the seal from the ingress of concrete during the pour.

Jointing and Detailing – In Line Joints



Overlap the Gas Barrier to a minimum of 150mm. Place a strip of Rhinoplast LT Jointstrip on the lower layer, having removed the plastic release film from the tape and press down firmly.



Remove the release paper and apply pressure to effect a seal. Expel any air trapped in the gasket. A roller is useful for this purpose



Secure the flap down with Rhinoplast High Tack single sided girth tape to secure the joint and protect it from the concrete pour.

Jointing and Detailing – Service Pipe Penetrations

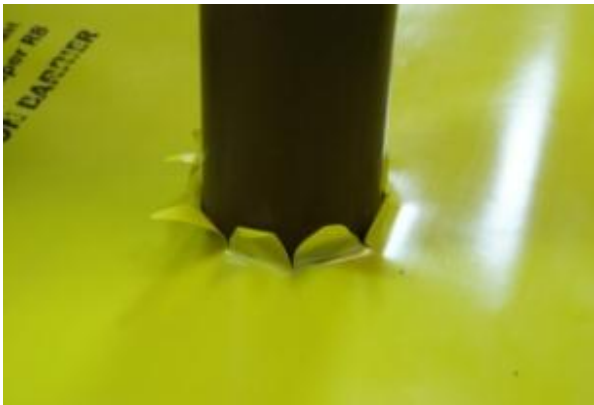

Cut around service pipe penetrations. Ensure this is positioned away from other laps or joints.

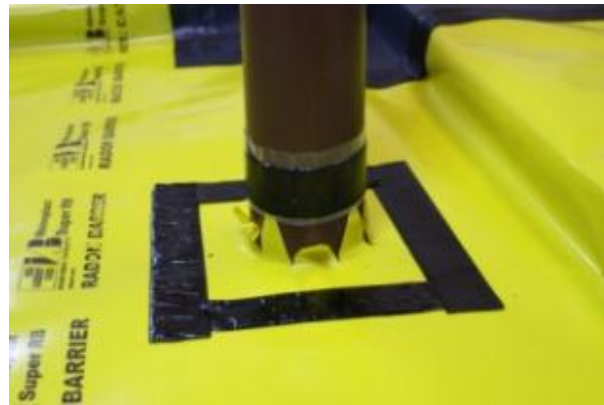

Place a strip of Rhinoplast LT Jointstrip around the pipe to line up with the top of the cloak, leaving the plastic release membrane to the outside in place. Place four strips of the tape to match the footprint of the top hat detail ensuring the tape is neatly butt jointed. Remove the release tape from the four base pieces.



Slide the top hat into position and push down on the flat section to effect a seal on to the tape. Carefully remove the plastic release membrane from the tape around the pipe by pulling it out.



Seal the outside of the bottom plate with four strips of Rhinoplast reinforced detail strip. Push down to expel air and effect a good bond.



Secure the top hat to the pipe with a stainless steel jubilee clip ensuring the clamp is located over the tape inside. Tighten to ensure a good seal.

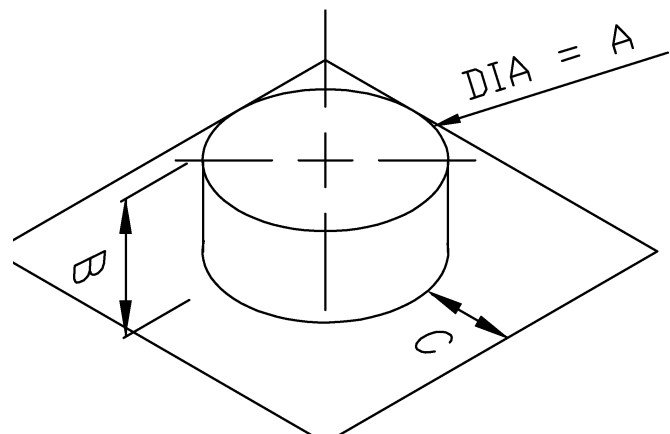

Jointing and Detailing – Internal Corners



It is possible to complete internal corners by using a “hospital fold” method. Ensure voiding behind membrane is minimal



Secure corners to hold in place with Rhinoplast Reinforced Detail Strip to ensure the detail remains stable.

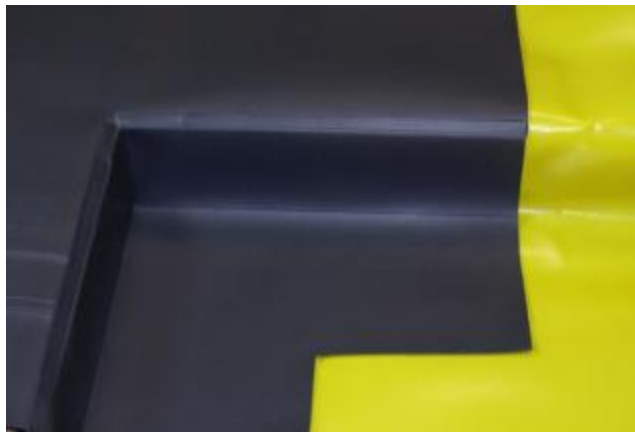

For ease of installation, internal corner cloaks are available



All preformed cloaks should be sealed with Rhinoplast LT Jointstrip ensuring butt joints are neat and accurate.



Over tape all cloaks with Rhinoplast Reinforced Detail Strip to stabilise the detail and prevent ingress of concrete during the pour.

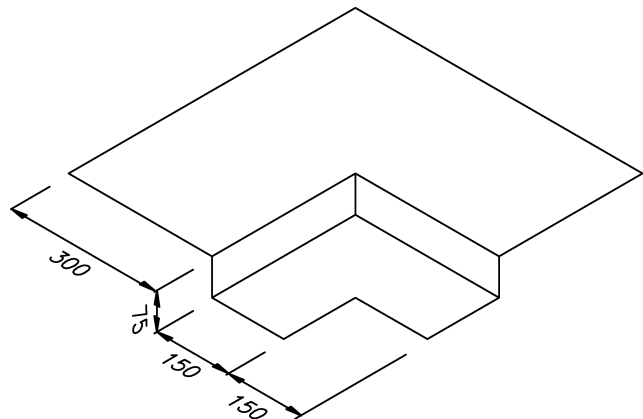

Optional preformed components available.

Jointing and Detailing – External Corners



For external corners, cut the membrane at 45 degrees away from the corner to release tension and achieve a neat fit.

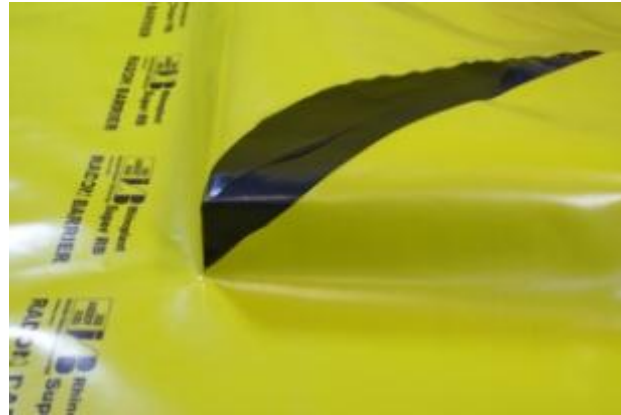

Tuck the membrane neatly into the floor/wall angle to prevent excess voiding behind. This will leave a gap in the membrane that can be sealed with single sided gas resistant detail strip.



Alternatively, preformed corner can be used and sealed. Place strips of Rhinoplast LT Jointstrip under the footprint of the cloak ensuring corners are butt jointed.

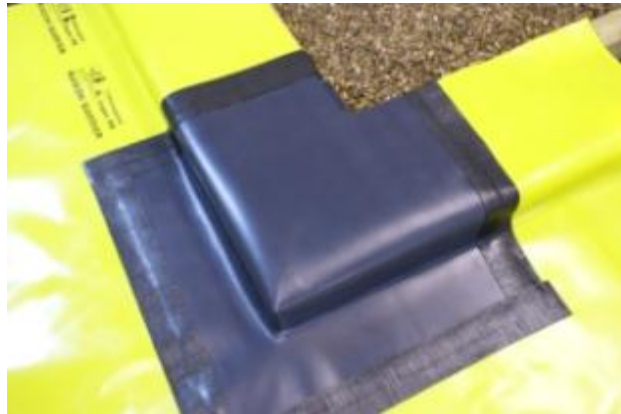

Remove the brown release paper on the Jointstrip and push the cloak onto the tape to effect a seal. Over-tape with Rhinoplast Reinforced Detail Strip.

Jointing and Detailing – Door Thresholds



Where door thresholds are necessary, a preformed cloak pair is available. Installed using the sealing and detailing method described for the corners.

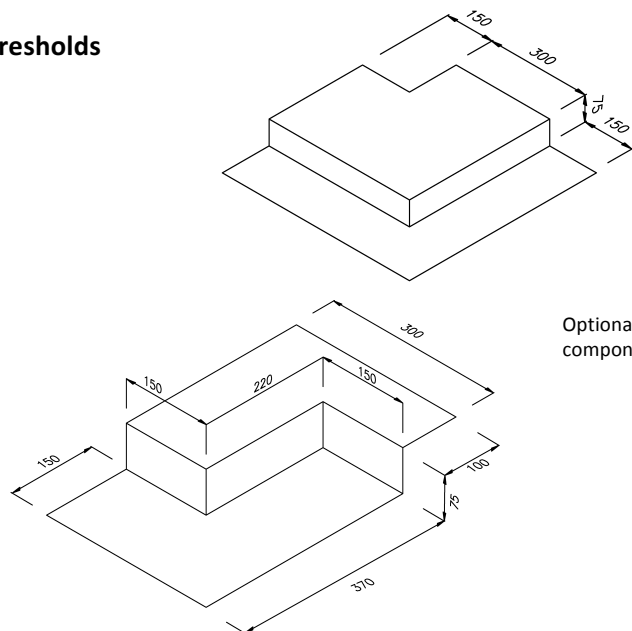

Optional preformed components available.

A final inspection should be made to ensure no damage has occurred. If damage is apparent, the area should be patched with gas membrane with a minimum of 150mm laps and sealed with Rhinoplast LT Jointstrip, then over-taped with Rhinoplast High Tack single sided girth tape.

Gas Compliance Table

Gas Membrane	BRE211 RADON	AMBER 1	AMBER 2 CS2+ / BS8485	CO2	VOC's / Hydrocarbons
Rhinoplast Ultra Radon Barrier	✓	✗	✗	✗	✗
Rhinoplast Super Gas Barrier	✓	✓	✗	✓	✗
Rhinoplast Evolution Gas Barrier	✓	✓	✓	✓	✓
Rhinoplast Evolution P-A	✓	✓	✓	✓	✓
Rhinoplast Evolution HD	✓	✓	✓	✓	✓

Useful references:

The Building Regulations Approved Document Part C 2004, CP 102: 1973 Code of practice for the protection of buildings against water from the ground.
BR211 " Radon – Guidance on protective measures for new buildings "
BRE414 "Protective measures for housing on gas---contaminated land "
CIRIA 665 Ground gas handbook 2009
CIRIA C748 Guidance on the use of plastic membranes as VOC vapour barriers
BS8485:2015 Code of Practice for the Characterization and Remediation from Ground Gas in Affected Developments
NHBC " Guidance on methane and carbon dioxide " and technical extra April 2016, issue 20.



Gas Barrier Membranes & Ancillaries

Rhinoplast Ultra Radon

A monolithic LDPE barrier designed primarily for use with Radon gas. Fully Radon gas tested and approved by NSAI (IAB) Meets the requirements of BRE211.

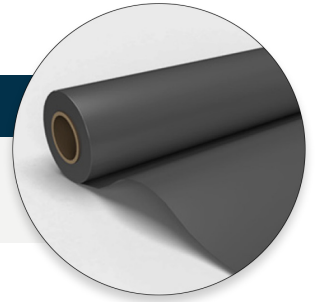

Rhinoplast Super

A monolithic hybrid co-polymer barrier giving excellent performance. Fully tested for Radon, Methane and CO2. Approved by NSAI (IAB) Exceeds the requirements of BRE211. Complies with NHBC Amber 1 installations. CS2 dependant on construction type.

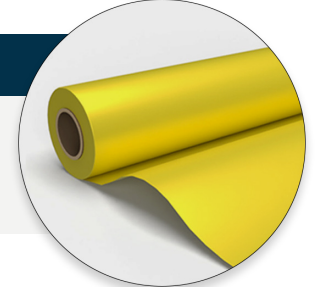

Rhinoplast Evolution Gas Barrier

Rhinoplast Evolution is a high specification co-extruded multi-layer barrier specifically developed for use on construction sites contaminated by Volatile Organic Compounds, Hydrocarbons and other ground gasses such as Methane, Radon and CO2. Complies with BS8485:2015 Table 7 CS2



Rhinoplast Evolution HD

Rhinoplast Evolution HD Gas Barrier is a high specification chemically resistant co-extruded multi-layer membrane engineered to provide exceptional protection on construction sites contaminated by volatile organic compounds, hydrocarbons, and ground gases such as methane, radon, and CO2.



Rhinoplast Evolution P-A

A pre-applied fully bonded waterproofing gas barrier membrane combined with a heavy-duty virgin polypropylene geotextile providing a fully concrete bonded system in basement and below ground structures.

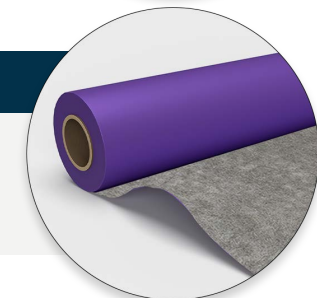

Tapes & DPC



Rhinoplast LT Jointstrip
50mm / 100mm



Rhinoplast
Reinforced Detail
Strip



Rhinoplast High
Tack Girth Tape



Rhinoplast Gas
Resistant Detail Strip



Rhinoplast
Evolution Gas DPC



Flexi-load
Radon Gas DPC